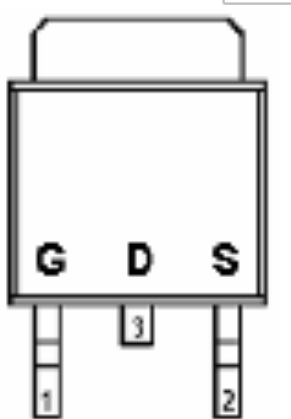

**DESCRIPTION**

STN454D is the N-Channel logic enhancement mode power field effect transistor which is produced using high cell density, DMOS trench technology. The STN454D has been designed specially to improve the overall efficiency of DC/DC converters using either synchronous or conventional switching PWM controllers. It has been optimized for low gate charge, low  $R_{DS(ON)}$  and fast switching speed.

**PIN CONFIGURATION (D-PAK)**
**TO-252**

**PART MARKING**

**FEATURE**

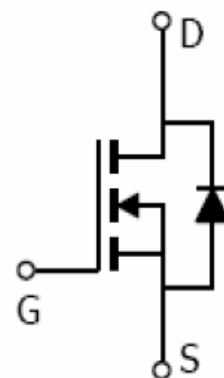
- 40V/12.0A,  $R_{DS(ON)} = 25m\Omega$  (Typ.) @ $V_{GS} = 10V$
- 40V/6.0A,  $R_{DS(ON)} = 27m\Omega$  @ $V_{GS} = 4.5V$
- Super high density cell design for extremely low  $R_{DS(ON)}$
- Exceptional on-resistance and maximum DC current capability
- TO-252 package design



**Y : Year Code**  
**A : Produce Code**  
**B : Process Code**

**STN454D**

N Channel Enhancement Mode MOSFET

10.0A

**ABSOLUTE MAXIMUM RATINGS** (Ta = 25°C Unless otherwise noted )

| Parameter                                    | Symbol | Typical         | Unit |
|--|--------|-----------------|------|
| Drain-Source Voltage                         | VDSS   | 40              | V    |
| Gate-Source Voltage                          | VGSS   | ±20             | V    |
| Continuous Drain Current<br>(TJ=150°C)       | ID     | TA=25°C<br>12.0 | A    |
|  |        | TA=70°C<br>10.0 |      |
| Pulsed Drain Current                         | IDM    | 30              | A    |
| Continuous Source Current (Diode Conduction) | IS     | 12              | A    |
| Power Dissipation                            | PD     | TA=25°C<br>50   | W    |
|  |        | TA=70°C<br>25   |      |
| Operation Junction Temperature               | TJ     | 150             | °C   |
| Storage Temperature Range                    | TSTG   | -55/150         | °C   |
| Thermal Resistance-Junction to Ambient       | RθJA   | 60              | °C/W |



**STN454D**



N Channel Enhancement Mode MOSFET

10.0A

**ELECTRICAL CHARACTERISTICS** ( Ta = 25°C Unless otherwise noted )

| Parameter                       | Symbol        | Condition  | Min | Typ      | Max       | Unit |
|---------------------------------|---------------|--|-----|----------|-----------|------|
| <b>Static</b>                   |               |  |     |          |           |      |
| Drain-Source Breakdown Voltage  | $V_{(BR)DSS}$ | $V_{GS}=0V, I_D=10mA$  | 40  |          |           | V    |
| Gate Threshold Voltage          | $V_{GS(th)}$  | $V_{DS}=V_{GS}, I_D=250\mu A$  | 1.0 |          | 2.5       | V    |
| Gate Leakage Current            | $I_{GSS}$     | $V_{DS}=0V, V_{GS}=\pm 20V$  |     |          | $\pm 100$ | nA   |
| Zero Gate Voltage Drain Current | $I_{DSS}$     | $V_{DS}=32V, V_{GS}=0V$  |     |          | 1         | uA   |
|                                 |               | $V_{DS}=32V, V_{GS}=0V$<br>$T_J=85^\circ C$                            |     |          | 5         |      |
| Drain-source On-Resistance      | $R_{DS(on)}$  | $V_{GS}=10V, I_D=12A$<br>$V_{GS}=4.5V, I_D=6A$                         |     | 25<br>27 | 31<br>36  | mΩ   |
| Forward Transconductance        | $g_{fs}$      | $V_{DS}=5V, I_D=12A$   |     | 25       |           | S    |
| Diode Forward Voltage           | $V_{SD}$      | $I_S=3.0A, V_{GS}=0V$  |     |          | 1.0       | V    |
| <b>Dynamic</b>                  |               |  |     |          |           |      |
| Total Gate Charge               | $Q_g$         | $V_{DS}=10V, V_{DS}=20$<br>$I_D=12A$                                   |     | 11       |           | nC   |
| Gate-Source Charge              | $Q_{gs}$      |  |     | 4.8      |           |      |
| Gate-Drain Charge               | $Q_{gd}$      |  |     | 1.8      |           |      |
| Input Capacitance               | $C_{iss}$     | $V_{DS} = 20V, V_{GS}=0V$<br>$F=1MHz$                                  |     | 850      |           | pF   |
| Output Capacitance              | $C_{oss}$     |  |     | 110      |           |      |
| Reverse Transfer Capacitance    | $C_{rss}$     |  |     | 75       |           |      |
| Turn-On Time                    | $t_{d(on)}$   | $V_{DD}=20V, R_L= 4\Omega$<br>$I_D=5.0A, V_{GEN}=10V$<br>$R_G=1\Omega$ |     | 6        | 12        | nS   |
|                                 | $t_r$         |  |     | 10       | 20        |      |
| Turn-Off Time                   | $t_{d(off)}$  |  |     | 20       | 36        |      |
|                                 | $t_f$         |  |     | 6        | 12        |      |

**TYPICAL CHARACTERISTICS**

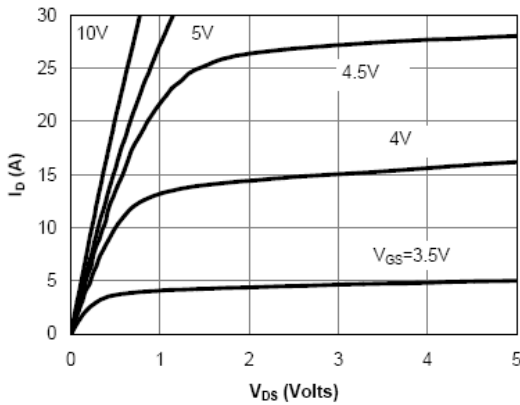

Fig 1: On-Region Characteristics

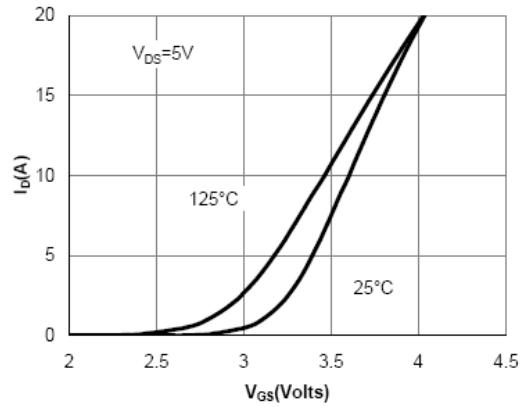

Figure 2: Transfer Characteristics

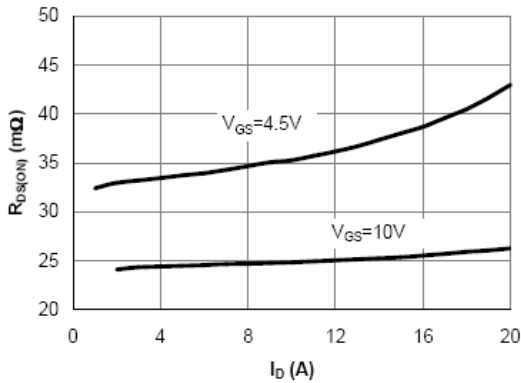

Figure 3: On-Resistance vs. Drain Current and Gate Voltage

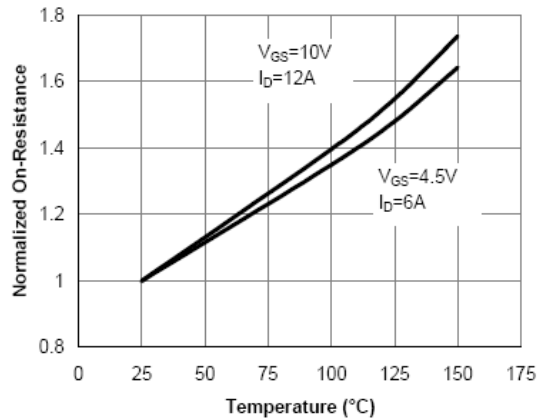

Figure 4: On-Resistance vs. Junction Temperature

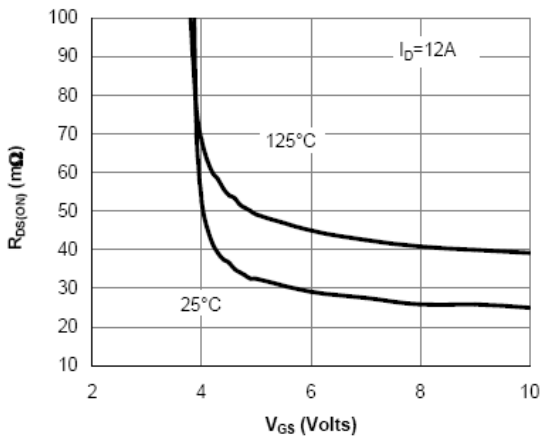

Figure 5: On-Resistance vs. Gate-Source Voltage

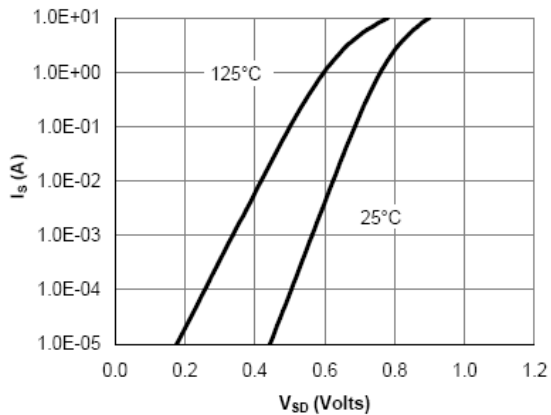

Figure 6: Body-Diode Characteristics

**TYPICAL CHARACTERISTICS**

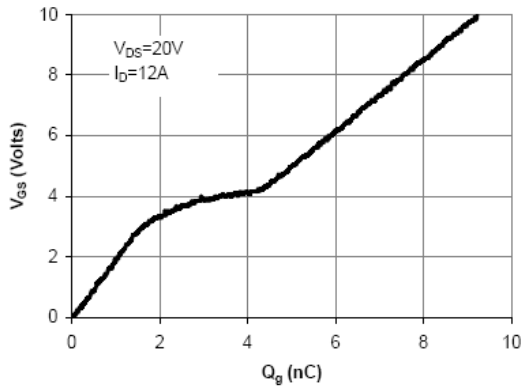

Figure 7: Gate-Charge Characteristics

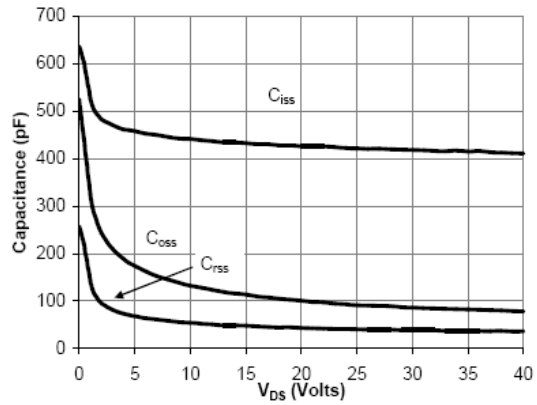

Figure 8: Capacitance Characteristics

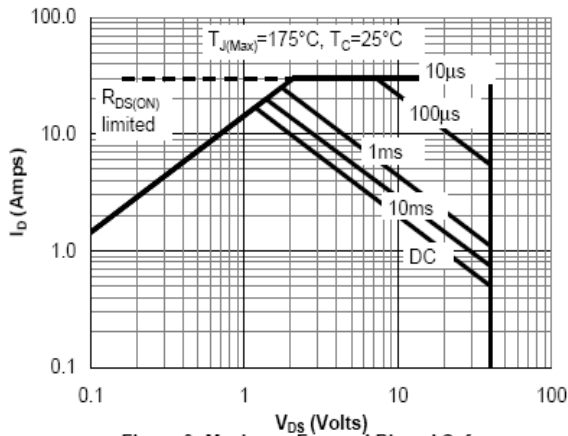

Figure 9: Maximum Forward Biased Safe Operating Area (Note F)

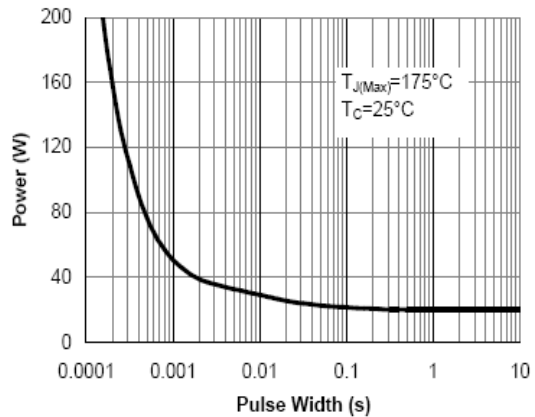

Figure 10: Single Pulse Power Rating Junction-to-Case (Note F)

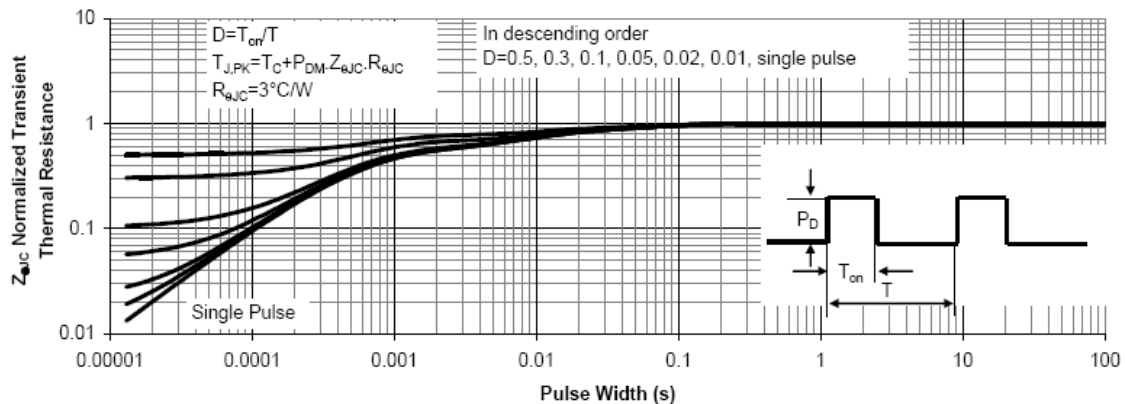
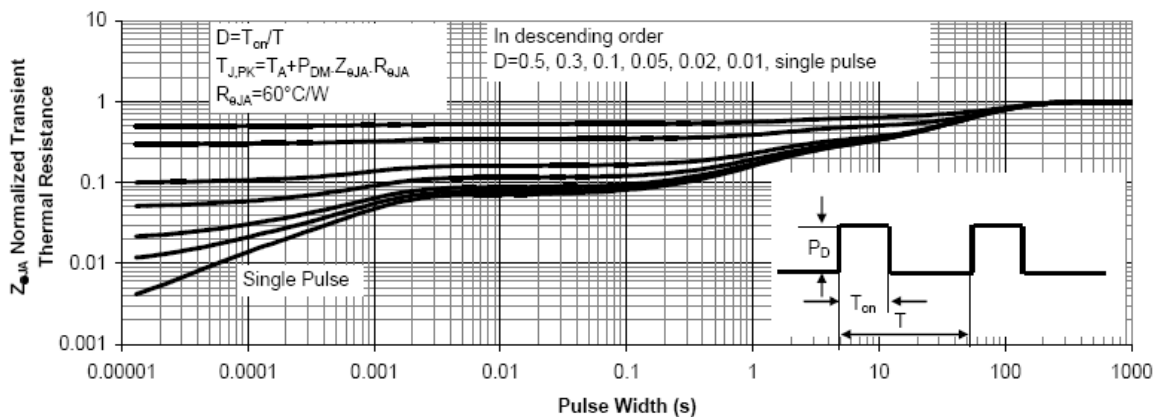
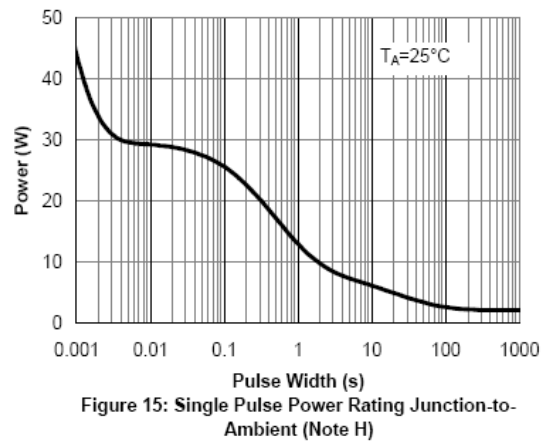
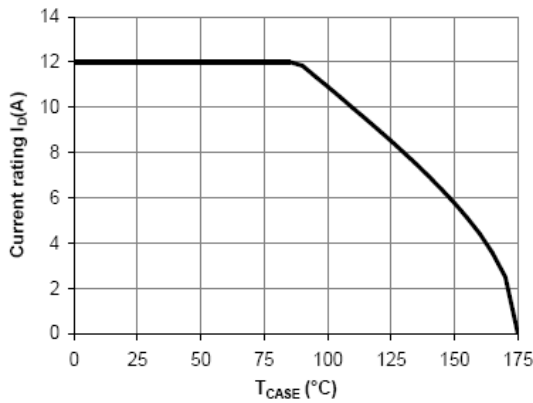
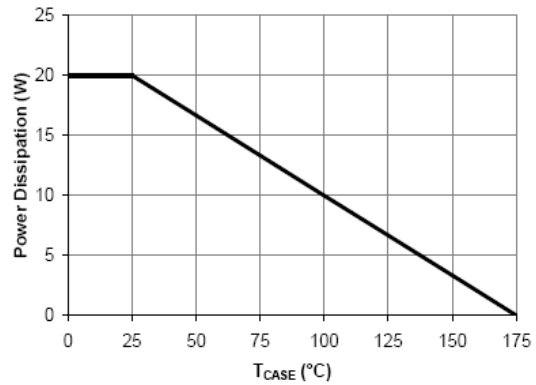
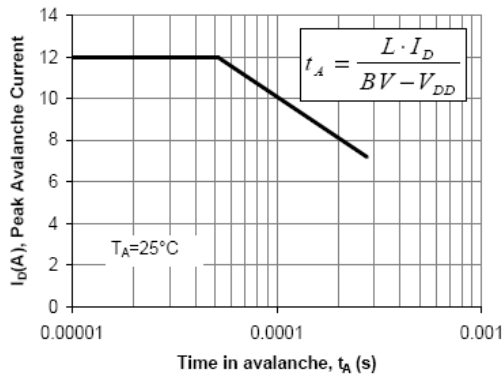
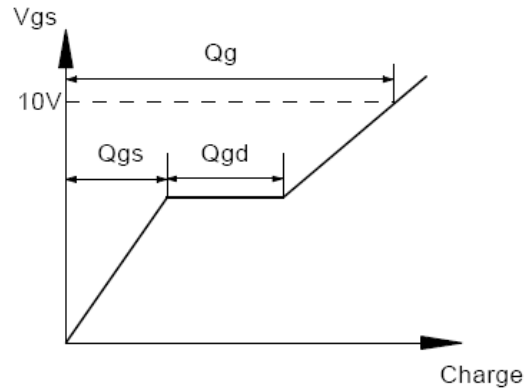
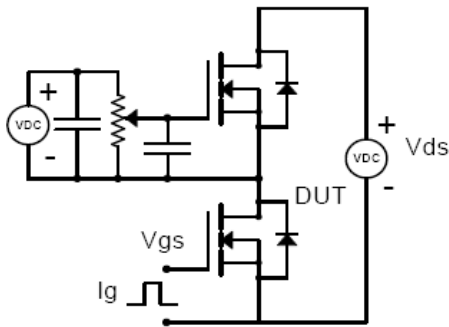

Figure 11: Normalized Maximum Transient Thermal Impedance (Note F)

**TYPICAL CHARACTERISTICS**

**GATE CHARGE TEST CIRCUIT & WAVEFORM**



**RESISTIVE SWITCHING TEST CIRCUIT & WAVEFORMS**

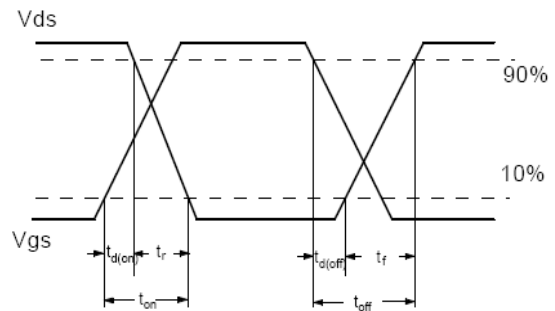
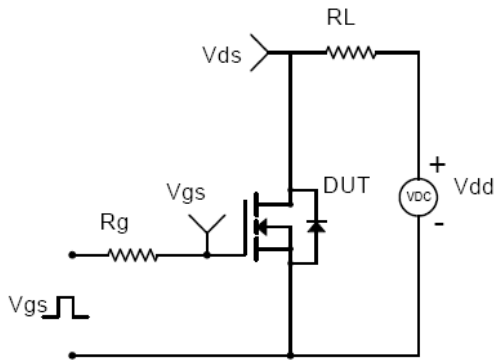

**UNCLAMPED INDUCTIVE SWITCHING (UIS) TEST CIRCUIT & WAVEFORMS**

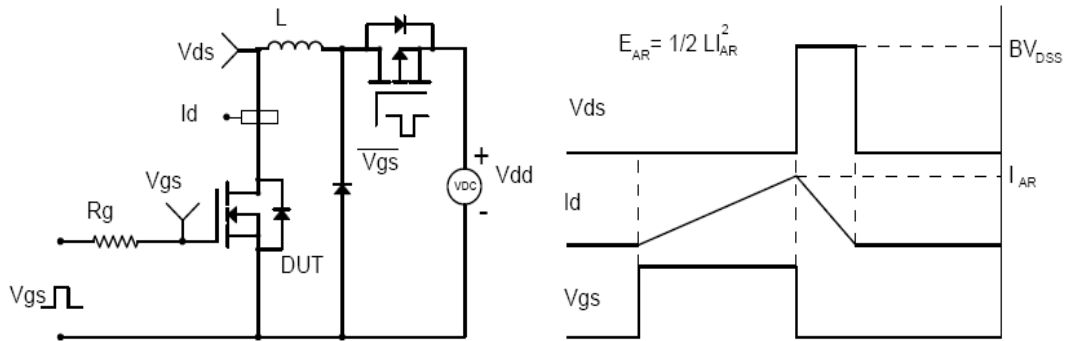

**DIODE RECOVERY TEST CIRCUIT & WAVEFORMS**

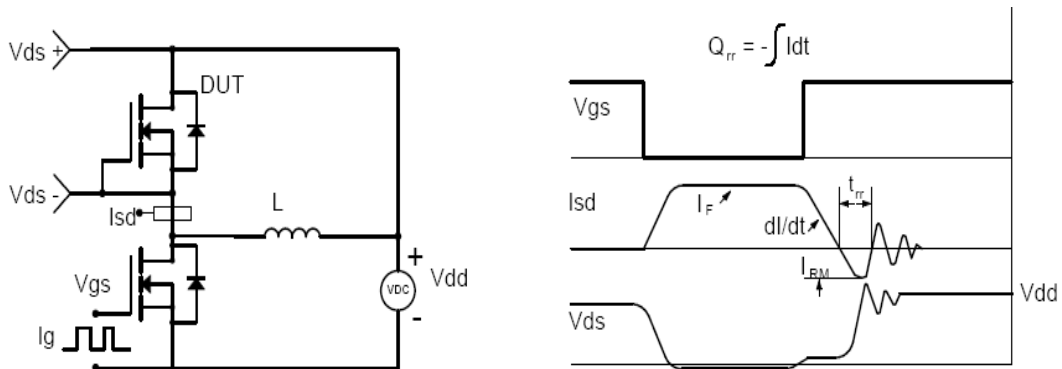

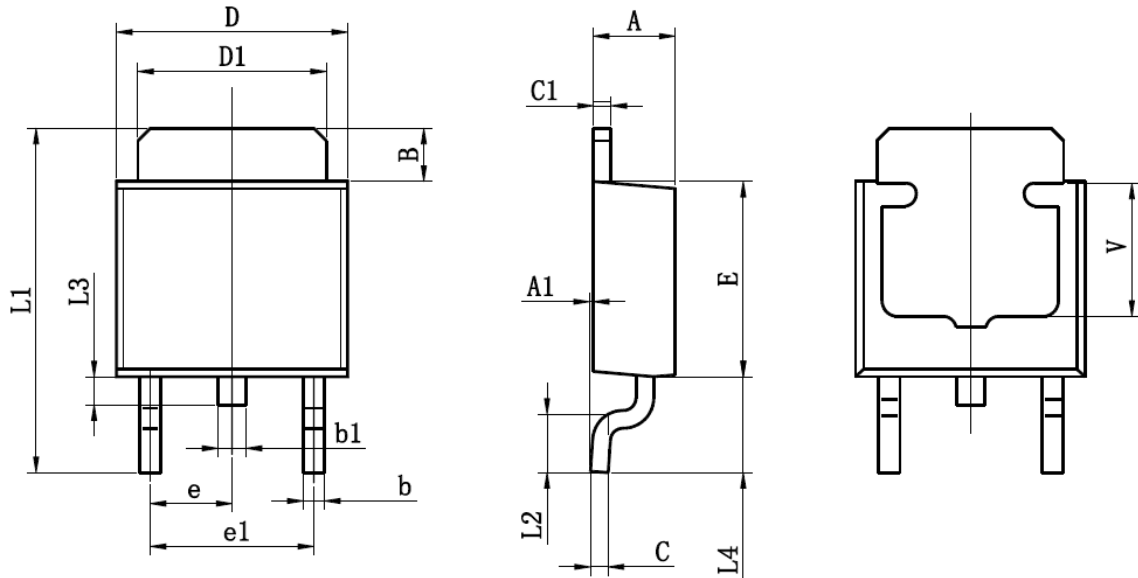

**TO-252-2L PACKAGE OUTLINE**

| Symbol | Dimensions In Millimeters |       | Dimensions In Inches |       |
|--------|---------------------------|-------|----------------------|-------|
|        | Min                       | Max   | Min                  | Max   |
| A      | 2.200                     | 2.400 | 0.087                | 0.094 |
| A1     | 0.000                     | 0.127 | 0.000                | 0.005 |
| B      | 1.350                     | 1.650 | 0.053                | 0.065 |
| b      | 0.500                     | 0.700 | 0.020                | 0.028 |
| b1     | 0.700                     | 0.900 | 0.028                | 0.035 |
| c      | 0.430                     | 0.580 | 0.017                | 0.023 |
| c1     | 0.430                     | 0.580 | 0.017                | 0.023 |
| D      | 6.350                     | 6.650 | 0.250                | 0.262 |
| D1     | 5.200                     | 5.400 | 0.205                | 0.213 |
| E      | 5.400                     | 5.700 | 0.213                | 0.224 |
| e      | 2.300TYP                  |       | 0.091TYP             |       |
| e1     | 4.500                     | 4.700 | 0.177                | 0.185 |
| L1     | 9.500                     | 9.900 | 0.374                | 0.390 |
| L2     | 1.400                     | 1.780 | 0.055                | 0.070 |
| L3     | 0.650                     | 0.950 | 0.026                | 0.037 |
| L4     | 2.550                     | 2.900 | 0.100                | 0.114 |
| V      | 3.80REF                   |       | 0.150REF             |       |